

[WWW.FERRISCATWHEEL.COM](http://WWW.FERRISCATWHEEL.COM)

# **FERRIS CAT WHEEL**

## **Assembly Instruction Manual**

# Items Check List

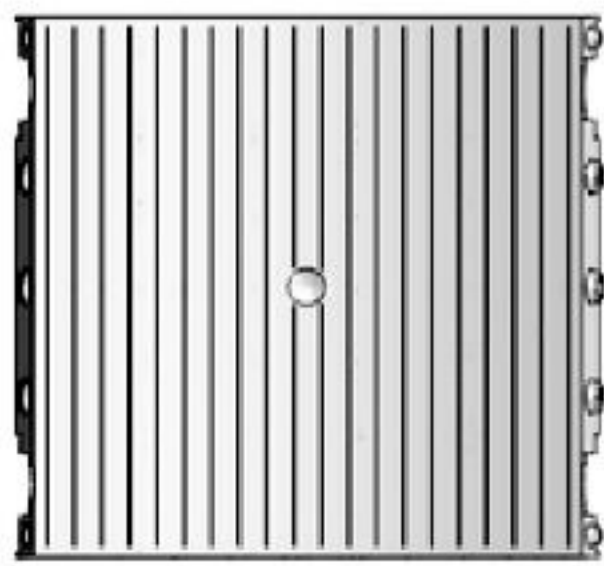

A : 12 pcs

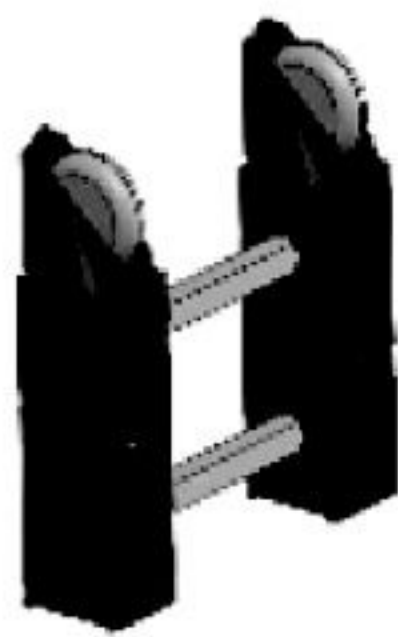

B : 2 pcs

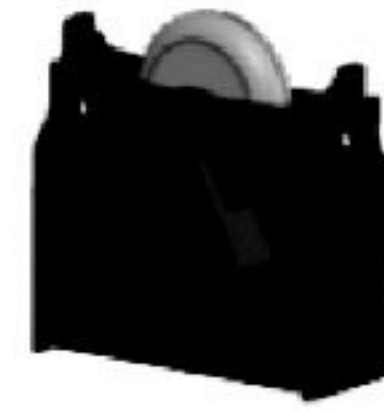

C : 2 pcs

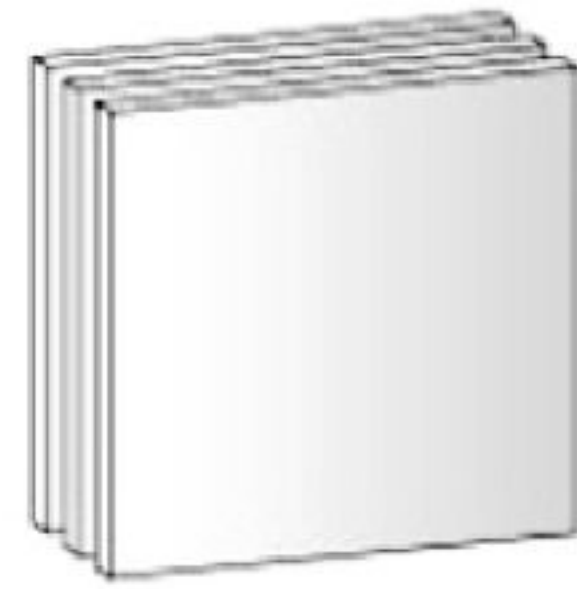

D: 12 pcs



E : 4 pcs



F: 24 pcs



G : 48 pcs



H : 48 pcs



I : 24 pcs



J : 1 pc



K : 1 pcs



L : 1 pc



M : 8 pcs

A : White part for cat wheel body  
F : Bolt  
L : 10mm Combination Wrench

B : Side Stand  
H : Rectangular washer  
M : Bolt set for aluminium bar assembly

C : Center stand  
I : Lock Nut

D : EVA foams  
J : Rubber Mallet

E : Aluminium bar  
K : Allen Key

## STEP 1

1. Align hole in B1 and B2 with hole in E1-E4, and secure with L.
2. Align hole in C with hole in E1-E4, and secure them with L as well.

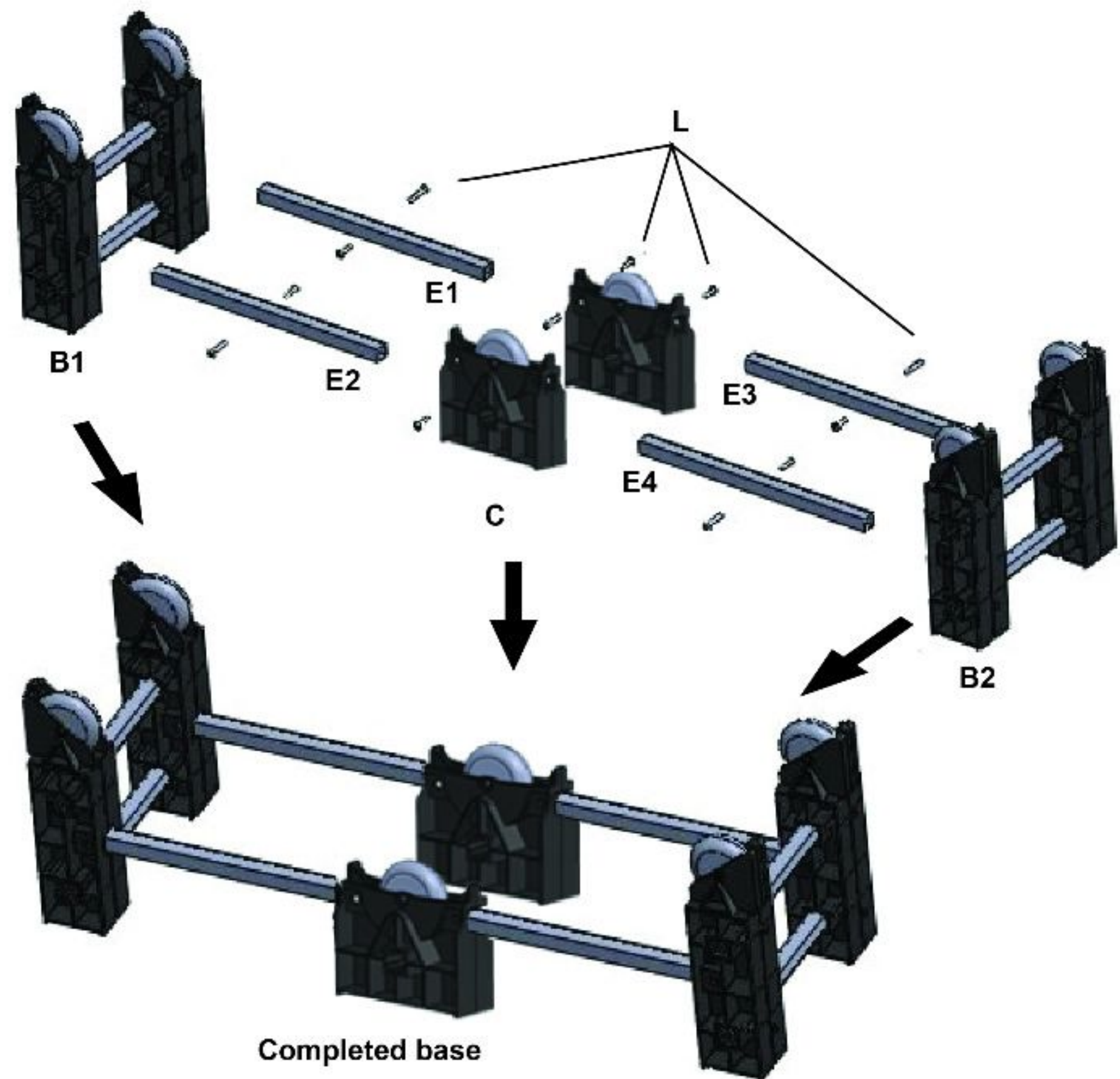

## STEP 2

1. Join white A segments as shown. Make sure the male & female parts fit perfectly.

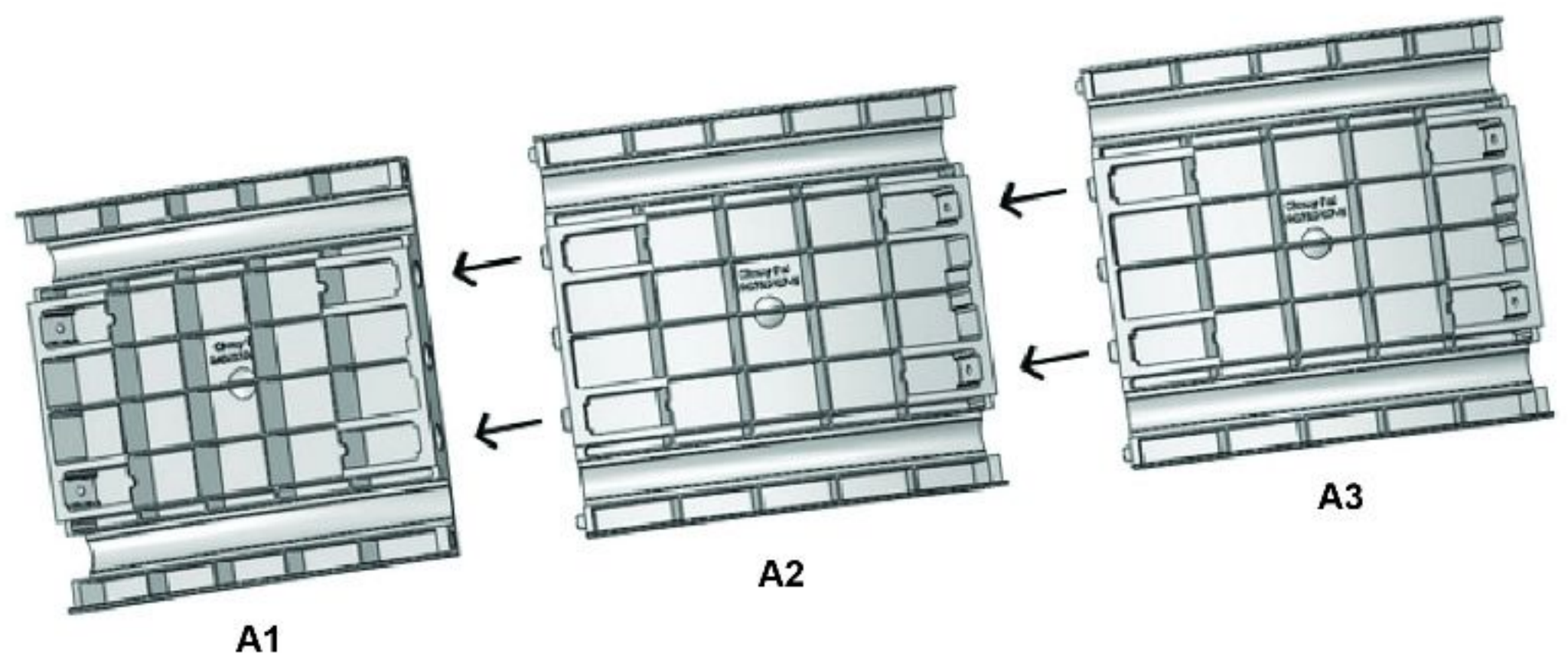

### STEP 3

1. Insert Bolt Assemblies with combination (as shown below) into the seam receptacles.
2. Insert allen key into the bolt to hold it steady, while using the wrench to tighten the lock nut. Ideal tightness is achieved when bolt protrudes 1mm from the lock nut.

Tip :  
You can place a round washer over the protruding bolt to check if ideal tightness has been achieved.

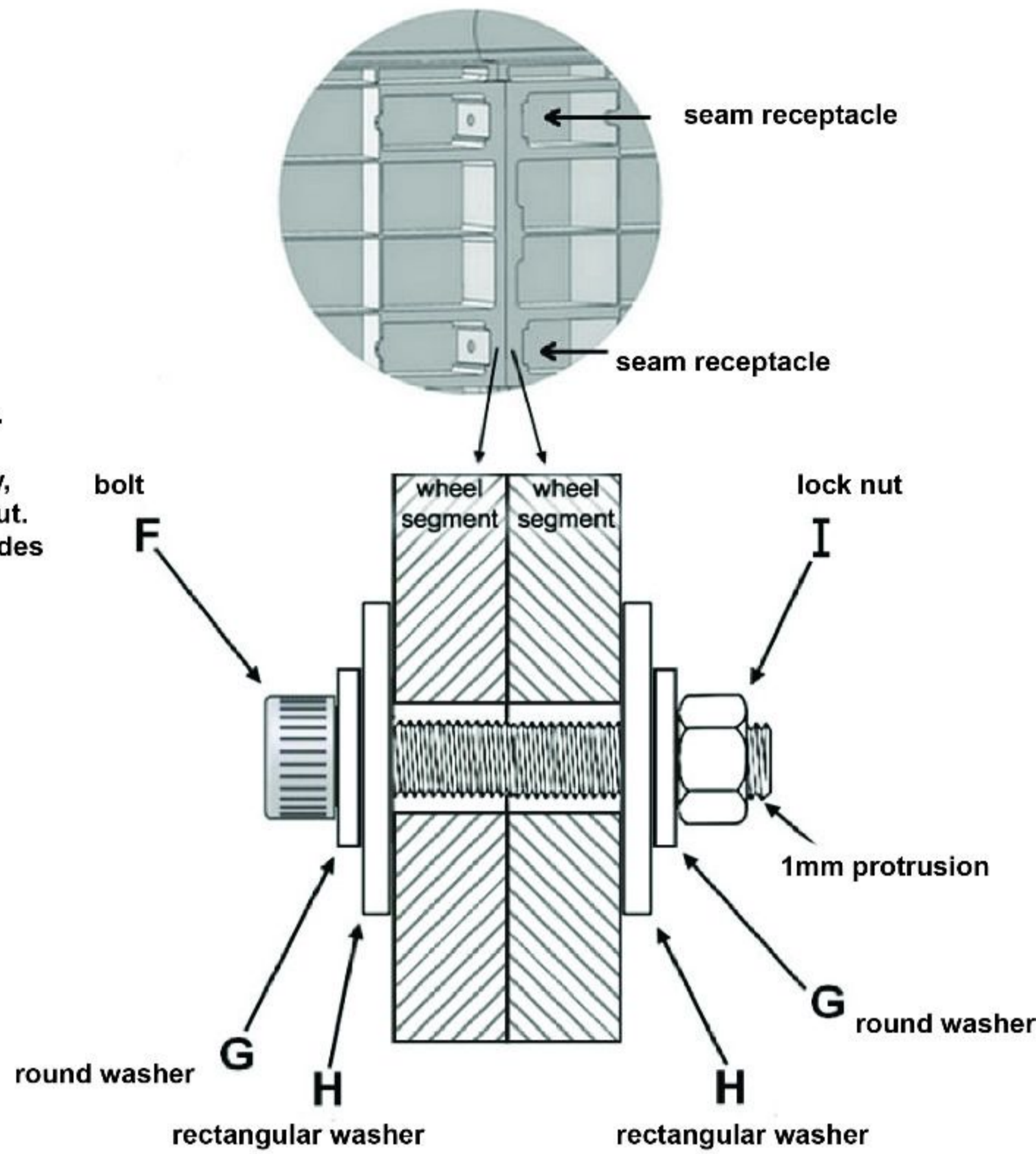

### STEP 4

1. Repeat step 2 & 3 for the rest of the item A in order to form the structure as figure 3.

**IMPORTANT :**  
The wheel must be placed flat on the floor during assembly - and whenever it is necessary to lift it from its base.

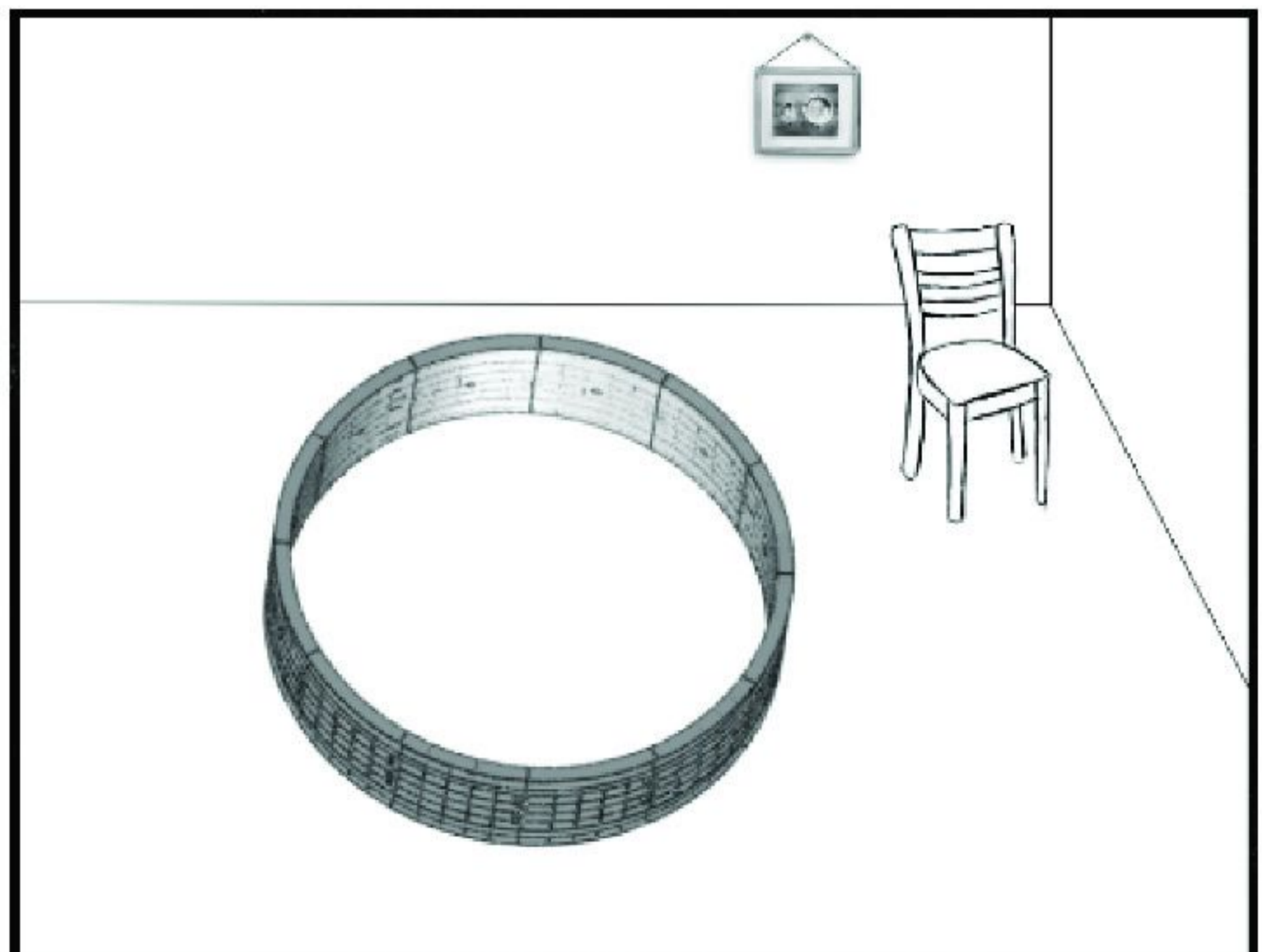

## STEP 5

Lift the wheel structure (easier with 2 people).  
Align the tracks to the wheelbase skatewheels.  
Gently lower into position

Roll the wheel to ensure proper track alignment  
and smooth rotation.

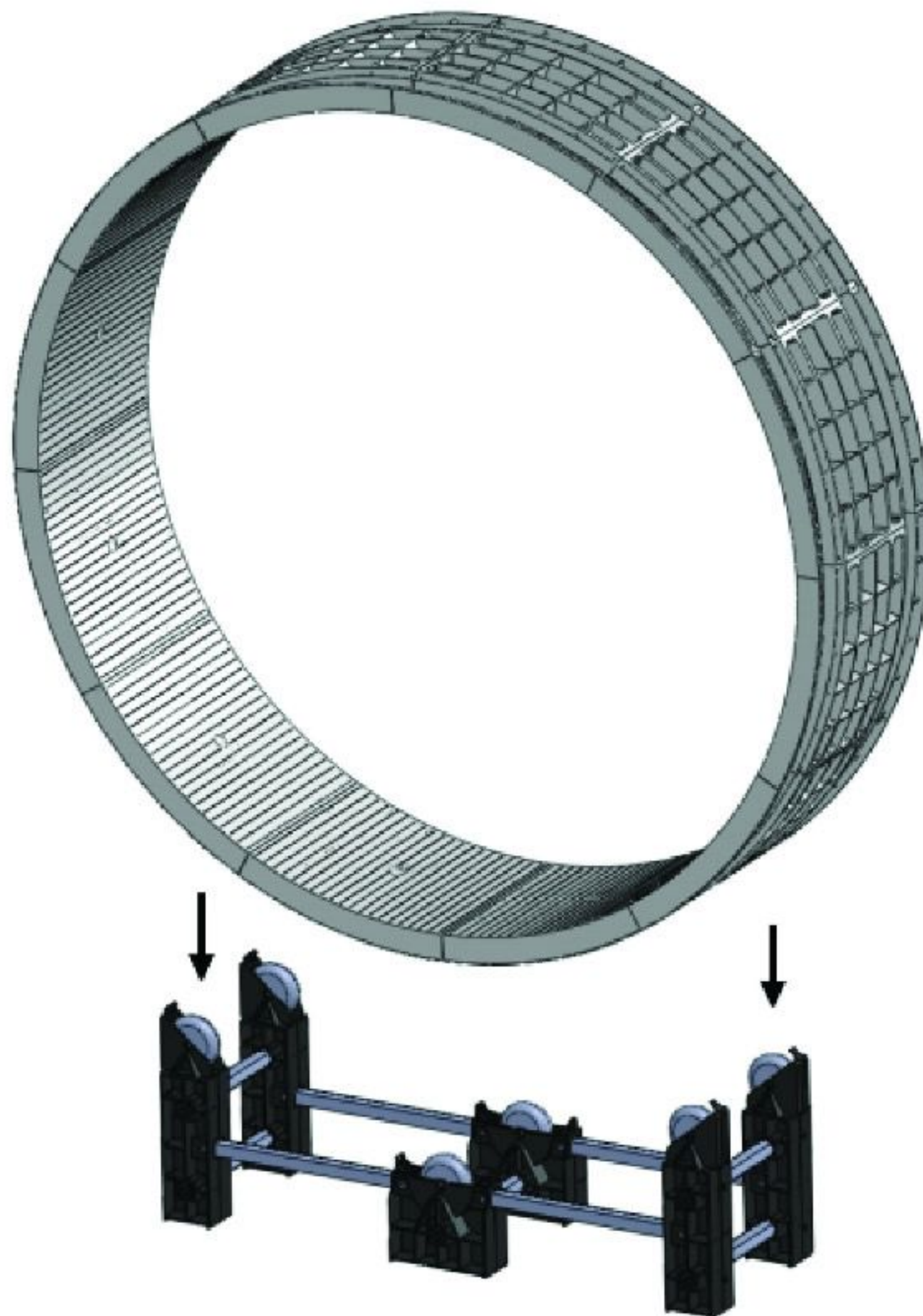

## STEP 6

1. Apply the self-adhesive EVA FOAM C1 throughout the whole structure.
2. Each piece of EVA foams shall be applied onto only one piece of A part, do not overlap the seam between two pieces of A.

### Tips :

1. The self adhesive EVA foams are not square, fit the longer edge of the EVA foam along the edge of the wheel.
2. To ensure consistent shading of the EVA foams, check each piece is correctly oriented. If necessary, rotate through 180 degrees before permanent adhesion.

